



ACHIEVING FASTER SWITCHING WITH COTOMOS[®] MOSFET RELAYS

How to get a faster response from a Solid State MOSFET Relay

Solid State Relays (SSRs) are well suited for switching test signals in Automated Test Equipment (ATE) applications given their compact size, which allows smaller test systems to be developed. In applications like these, testing speed is crucial, as it decreases overall testing time and thus increases the number of devices tested within a given timeframe. While SSRs can be designed to have short Turn-ON times (e.g., Coto Technology's **CotoMOS[®] CS135** has a Turn-ON time of 20-100uSec), there may be a case where a different spec takes precedence and an SSR that can meet that spec has a longer Turn-ON time. For example, the previously mentioned CS135 can only switch up to 100mA of current. What happens if a higher current capability is required and any part numbers that can withstand it have longer Turn-ON times? As another example, Coto's **C236S** can switch up to 2.5A, but its Turn-ON time can be as high as 3mSec (up to 150 times higher than the CS135!). In this App Note, we will show how to work around this and get a faster response from an SSR.

"...while it may be tempting to increase the driving current (by using a smaller input resistance in series with the LED) to achieve a shorter Turn-ON Time, there is a trade-off to consider."

Let's start with a quick refresher. CotoMOS[®] MOSFET Solid State Relays (SSR) operate by means of an LED (across its input terminals) and a Phototransistor (across its output terminals). When a voltage is applied to the input, a current is generated that turns the LED ON, which, in turn, causes the output to switch within a given length of time.

An SSR's Datasheet will show several relevant specs that can help one to understand the relay's switching capability. These include:

- The **Maximum Continuous** and **Peak LED Currents**, along with the maximum duration.
- Standard recommended **Operation LED Current**.
- Typical and maximum **Turn-ON Time** (time from the application of the input signal to when the output has fully switched).
- The relationship between LED current and Turn-ON time.

Table 1 and Figure 1 show an example of these specs obtained from **Coto's C236S SSR Datasheet**. As shown in Figure 1, a higher LED forward current will reduce the Turn-ON time of the SSR. However, while it may be tempting to increase the driving current (by using a smaller input resistance in series with the LED) to achieve a shorter Turn-ON Time, there is a trade-off to consider. A higher continuous Operation LED Current will increase the overall power consumption, and the increased stress could make the LED degrade faster over time.

PARAMETER	SYMBOL	VALUE
Max Continuous LED CURRENT	I_{F_MAX}	50mA
Peak LED Current (f=100Hz, Duty Cycle=1%)	I_{FP}	1000mA
Operation LED Current	I_{FON}	0.5-3mA
Turn-ON Time	T_{ON}	3.0ms (max)

Table 1: Specs from CotoMOS[®] C236S Datasheet

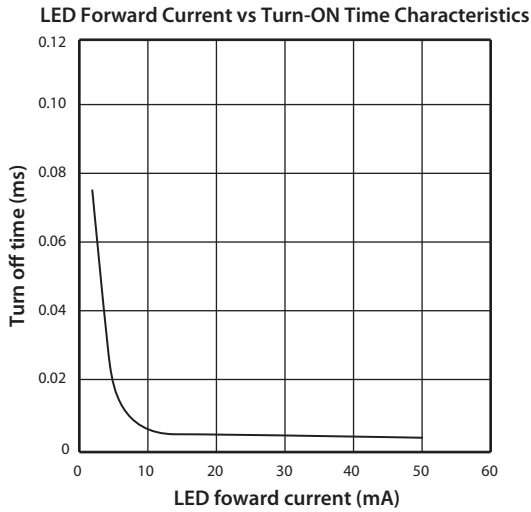

Figure 1: Relationship between LED Forward Current and Turn-ON Time for Coto's C236S

One way to get around this is to apply a large current pulse for a very short amount of time and then reduce it for steady state operation. The pulse's peak current should be under the Peak LED Current spec, and its duration should be no longer than the maximum specified on the SSR's Datasheet. A compact, cost-effective solution for this is to add a resistor and a capacitor to the SSR's input as shown in Figure 2 (R_2 and C_1 inside the dashed rectangle).

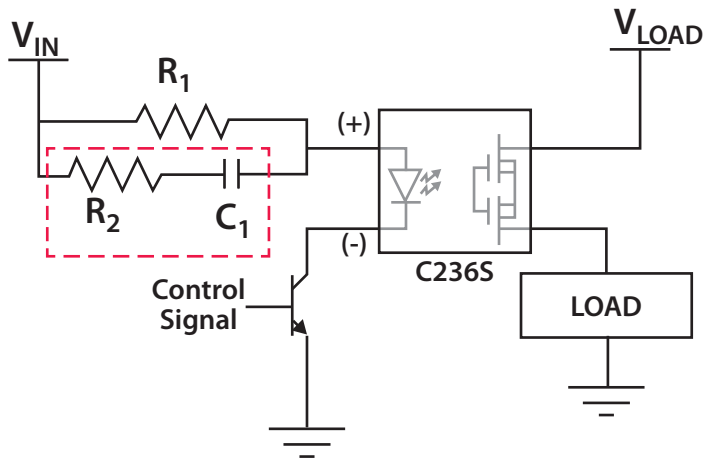

Figure 2: Circuit to ensure faster Turn-ON with a CotoMOS® MOSFET Solid State Relay (SSR)

The control signal drives the negative pin on the input (i.e., LED cathode) to ground, allowing current to flow through the input LED. When only R_1 is in series with the input LED of the SSR (i.e., No R_2 or C_1 present), the Turn-ON time will depend on the amount of current passing through the LED, as seen in Figure 1. This current (we'll call it I_{SS}) is determined by V_{IN} , R_1 and any voltage drops across the driver used to activate the SSR.

When R_2 and C_1 are added in parallel with R_1 , the startup of the SSR will be different. C_1 , being initially discharged (0V), will generate an inrush current pulse once V_{IN} is applied, with a momentary peak (I_{PEAK}) that is much higher than I_{SS} . This higher current peak will turn ON the LED faster. Once C_1 is fully charged, it will stop the flow of current, and any current will flow through R_1 instead. The trick is to select R_1 to define I_{SS} and R_2 to define I_{PEAK} . The value of C_1 is selected to set the width (i.e., duration) of the inrush current pulse. The peak and duration of this pulse should be within the Datasheet specs as shown in Table 1.

Let's look at an example scenario where this is put into practice. An experiment was conducted with two **C236S** SSRs, both controlled by an ULN2803A Darlington Array, and a V_{IN} of 5V. The first C236S only had a 480 Ohm resistor (i.e., R_1) connected to its input. Considering the voltage drops from the ULN2803 and the C236S LED (~1.2V each), the steady state LED current is obtained by the following equation:

$$I_{SS} = (5V - 1.2V - 1.2V) / 480 \text{ Ohm} = \mathbf{5.4 \text{ mA}}$$

The second C236S was configured as shown in Figure 2, with $R_1 = 480 \text{ Ohms}$, $R_2 = 5 \text{ Ohms}$ and $C_1 = 1 \mu\text{F}$. These values ensure the same steady state current as the first C236S, but with an initial peak current of:

$$I_{PEAK} = (5V - 1.2 - 1.2) / 5 = \mathbf{520 \text{ mA}}$$

Figure 3 below shows the results of this experiment. The blue curve is the control signal applied to the inputs of the ULN2803, whereas the orange and green curves are the outputs of the **C236S** SSRs without the speed-up circuit and with the speed-up circuit, respectively. As seen in the image, the C236S with the speed-up circuit achieves a much faster switching time (~20 μSec .) than the circuit without (~700 μSec).

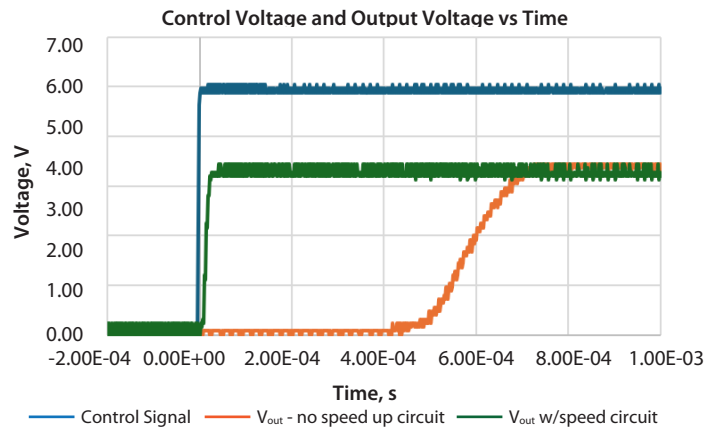

Figure 3: Results of experiment with two C236S SSRs with and without the circuit to speed up Turn-ON Time.

The time constant for this R_2/C_1 combination will be $50\text{Ohm} \times 1\mu\text{F} = \mathbf{1\mu\text{Sec}}$. Assuming 5 time constants (time to fully charge the capacitor), the current pulse width would be within $5\mu\text{Sec}$, well below the max spec of $100\mu\text{Sec}$ (100Hz with Duty of 1%) shown in Table 1.

An additional case was run keeping $R_1 = 480\text{ Ohms}$ but using $R_2 = 3.33\text{ Ohms}$ and $C_1 = 2\mu\text{F}$. This case showed an even faster Turn-ON time of around $\mathbf{10\mu\text{Sec}}$.

Conclusion

An SSR's Turn-ON time can be shortened by adding a simple, inexpensive RC circuit in parallel with the input current limiting resistor. The RC circuit generates a quick current pulse that turns ON the internal LED of the SSR faster, after which the current drops down to a lower, safer level. This achieves a "best of both worlds" scenario where a higher current can be applied to achieve a Faster Turn-ON, but without applying that current constantly, which can lead to a degradation of the input LED of the SSR. Care must be taken to select the RC components, such that the initial current pulse does not exceed the maximum current specs (peak and duration) outlined in the SSR's datasheet.

To learn more about Coto Technology's CotoMOS® MOSFET relay offerings, or for any other questions, please visit our website, at www.cototechnology.com